	INDIAN SCHOOL AL WADI AL KABIR		
Class: XII	Department: SCIENCE 2023 – 24 SUBJECT: ENGINEERING GRAPHICS		Date of submission: 06.06.2023
Worksheet WITH ANSWERS	UNIT 1: MACHINE DRAWING		Note: A4 FILE FORMAT
NAME OF THE STUDENT		CLASS & SEC: XII C	ROLL NO.

MULTIPLE CHOICE QUESTIONS

1.The distance moved by a nut or bolt in the axial direction in one complete rotation is called as--

- a) Pitch
- b)Lead
- c) crest
- d) None of the above

2. The machine parts which can be seperated only breaking the fastening is called as-----

- a) Temperory fastener
- b) Permanent fastener
- c) Screw thread
- d) Screw pair

3.A helical groove cut along the outer circumference of a cylinder is called a -----

- a) Fastener
- b) Nut
- c) Bolt
- d) Screw thread

4. The nut and bolt together is called as -----

- a) Screw pair
- b) Fastener
- c) Nut
- d) Bolt

5. The surface connecting crest and root is called as -----

- a) Flank
- b) Root
- c) Lead
- d) Pitch

6. Which type of thread is used in the neck of glass bottles -----

- a) BSW thread
- b) Metric thread
- c) Knuckle thread
- d) Square thread

7. In BSW thread the major diameter D is calculated using the formula?

- a) $D = 0.96P$
- b) $D = 0.86P$
- c) $D = 0.64P$
- d) $D = 0.61P$

8.----- is also called as unified thread

- a. Knuckle thread
- b. Metric thread
- c. Taper thread
- d. Square thread

9. Which one is a permanent fastener-----

- a) Nut
- b) Bolt
- c) Rivets
- d) Washer

10. A circular plate which provides a smooth bearing surface is called as -----

- a) Nut
- b) Bolt
- c) Washer
- d) None of the above

11. Nuts will have which type of threads-----

- a) Internal threads
- b) External threads
- c) V threads
- d) None of the above

Q12. to 16: Read the following paragraph and answer the questions given below

Varun's mother bought a new cookware set through online shopping, and when it got delivered the cookware handles were fixed with a special type of machine part. Being an engineering graphics student Varun sent the following image of that machine part to their Engineering Graphics teacher. Then the teacher explained everything about that part, which is called as Rivet. Analyze the figure and answer the following questions



12. Analyze the figure and identify which type of rivet head is shown in the figure?

- a) Snap head rivet
- b) Pan head rivet
- c) 60-degree CSK rivet
- 4.Flat head rivet

13. Rivet heads are which type of fasteners?

- a) Temporary fastener
- b) Permanent fastener
- c) Threaded fastener
- d) Unified fastener

14. In this type of rivet head, radius of head portion is calculated with a value of?

- a) $R = 0.7d$
- b) $R = 0.6d$
- c) $R = 1.5d$
- d) $R = 0.8d$

15. If $d = 20$ mm, find the value of the height of the head portion of rivet head?

- a) 14
- b) 16
- c) 18
- d) 32

16. A ----- is a simple round rod having head at one end.

- a) Stud
- b) Rivet
- c) Screw
- d) Nut

DESCRIPTIVE TYPE QUESTIONS

1. Draw to 1:1 the front elevation and side view of a hexagonal head bolt of M30 size, keeping the axis horizontal. Give standard dimensions.

2. Draw to scale 1:1 the standard profile of a BSW thread, taking enlarged pitch = 30 mm, Give standard dimensions.

3. Draw to scale 1:1 the standard profile of a metric thread (internal) taking enlarged pitch = 60 mm, Give standard dimensions.

4. Draw to scale 1:1 the front view and top view of a square head bolt of diameter 26 mm, keeping its axis vertical.

5. Sketch freehand, front view and side view of a stud with collar, keeping the axis vertical. Give standard dimensions.

6. Sketch freehand the front view and top view of a flat head rivet of diameter 20 mm, keeping its axis vertical. Give standard dimensions.

7. Sketch freehand the front view and top view of a cheese head screw of size M20, keeping its axis vertical. Give standard dimensions.

8. Sketch freehand the conventional representation of RH External V thread (Take $p = 5\text{mm}$)

ANSWER KEY – MULTIPLE CHOICE QUESTIONS	
1	b) Lead
2	b) Permanent fastener
3	d) Screw thread
4	a) Screw pair
5	a) Flank
6	c) Knuckle
7	a) $D = 0.96P$
8	b) Metric thread
9	c) Rivets
10	c) Washer
11	c) Washer
12	a) Snap head rivet
13	b) Permanent fastener
14	d) $R = 0.8d$
15	a) 14
16	b) Rivet

SOLUTIONS FOR DRAWINGS

1. (Hint : standard dimensions of hexagonal headed bolt should be calculated in terms of d)

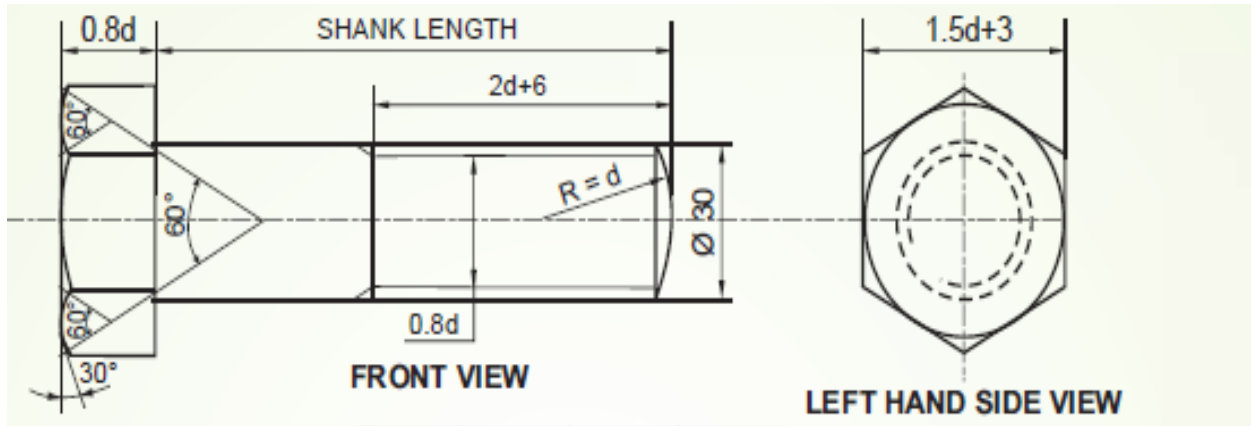

2. (Hint : Standard dimensions of BSW thread should be calculated with the pitch given = 30mm)

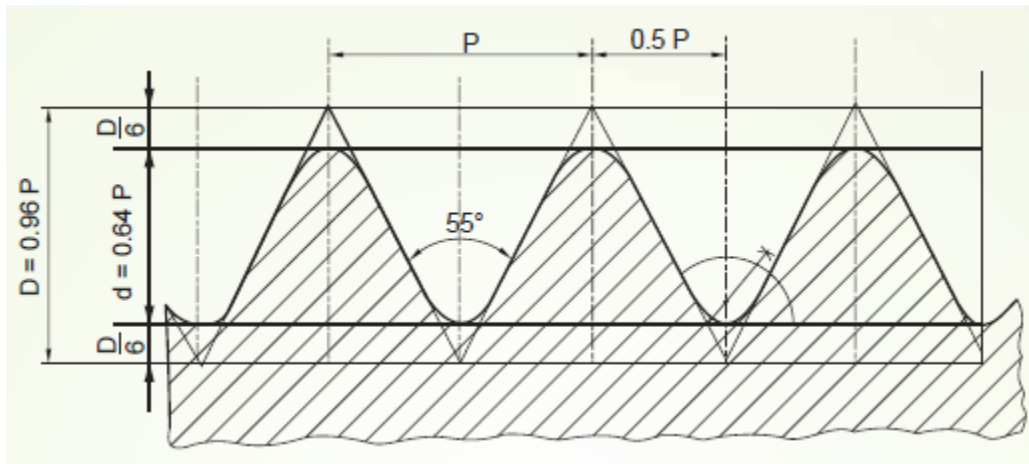

3. (Hint : Standard dimensions of Metric thread internal should be calculated with the pitch given = 60mm)

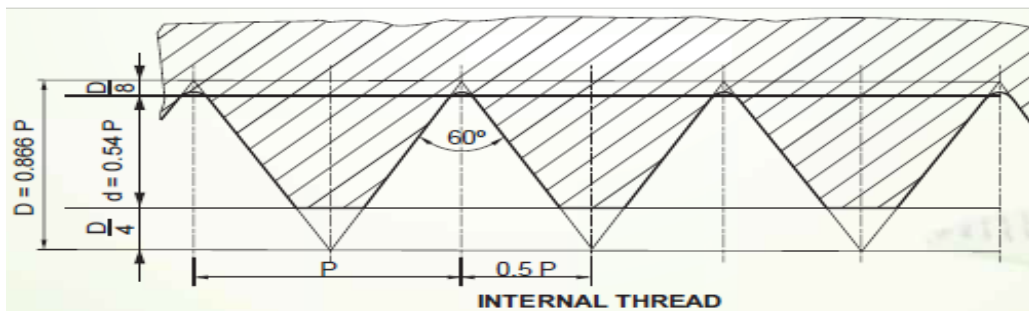

4. (Hint : Standard dimensions of square headed bolt in terms of d , $d = 26$ mm)

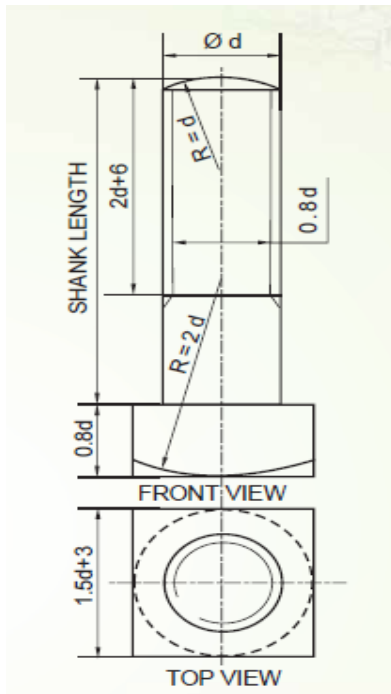

5. (Hint : Free hand sketch of stud with collar , d can be taken proportionately and calculate standard dimensions) .

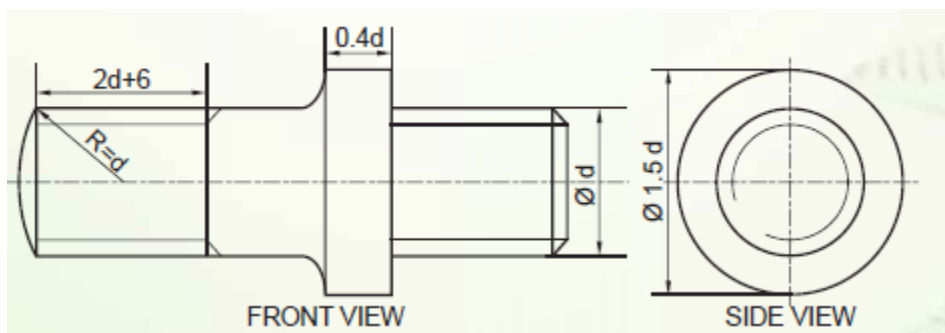

6. (Hint : Free hand sketch of flat head rivet ,stand dimensions calculated with $d = 20$ mm).

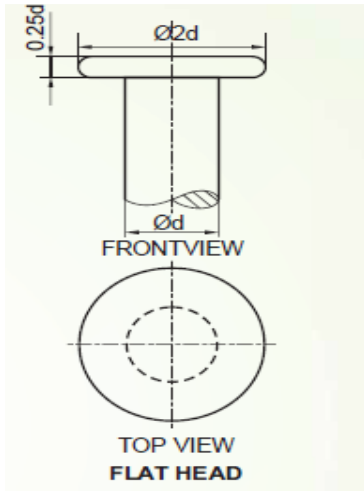

7.

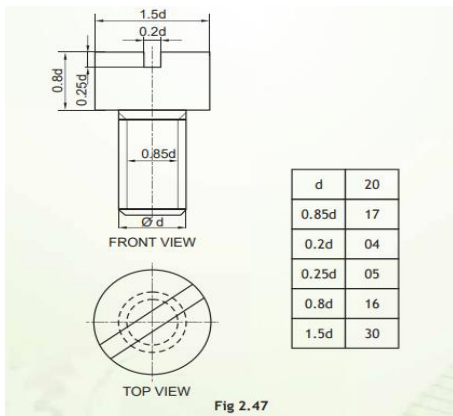

8.

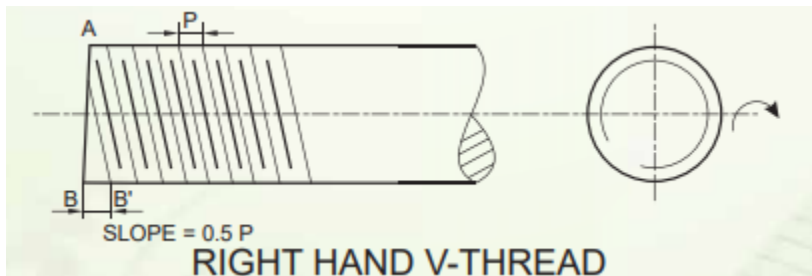

Prepared by:
Ms. Aiswarya Deepthi.P

Checked by:
HOD – SCIENCE & FRENCH